



Peerless Data Sheet

DT 115

115 DT 26 72 SF 8 ohm - Order ID: 810665

A classic among dome tweeters. This dome tweeter has been on the market for many years and is widely used and tested in studio monitors and high-end loudspeaker boxes. An all round tweeter for many different applications.

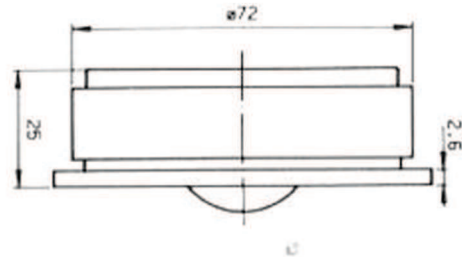
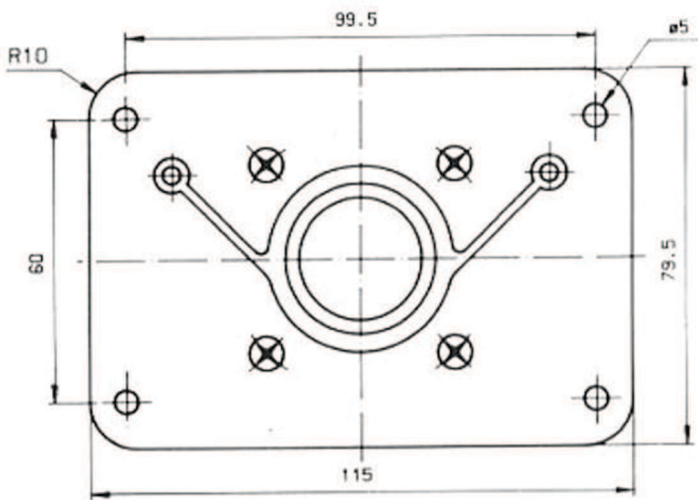
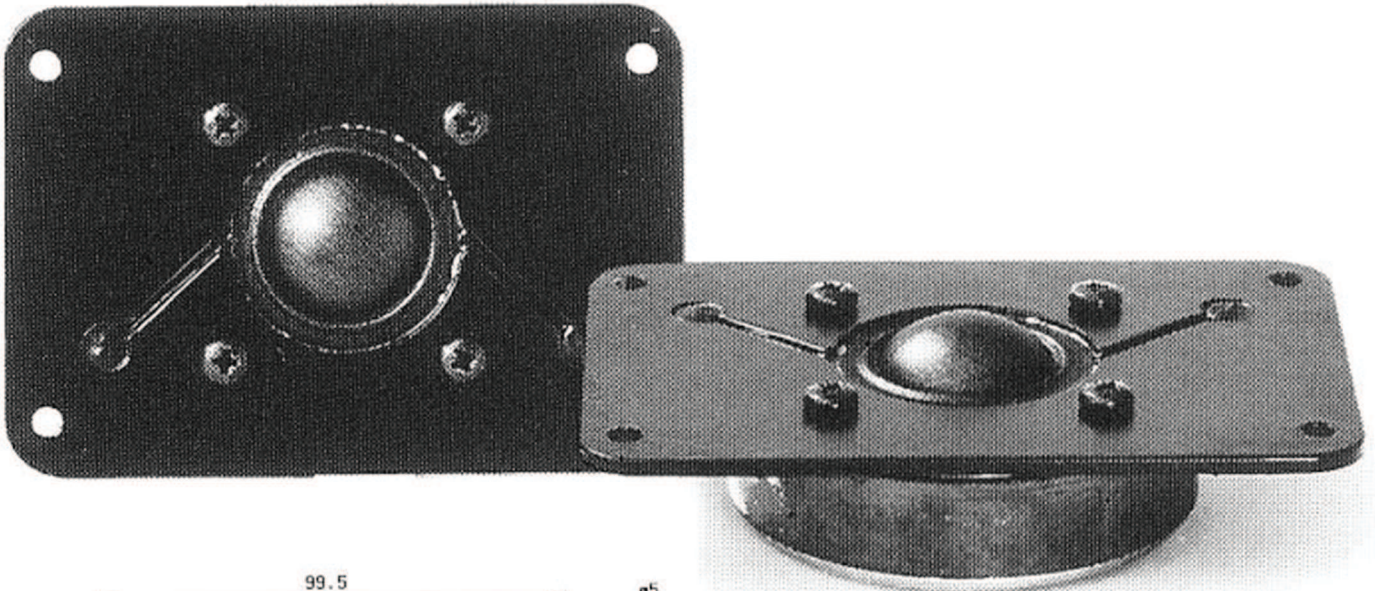

DT 115**Thiele Small parameters:**

Nominal impedance	Zn	(ohm)	8
Minimum impedance/at freq.	Zmin	(ohm/Hz)	6.3/4190
Maximum impedance	Zo	(ohm)	31.9
DC resistance	Re	(ohm)	6.8
Voice coil inductance	Le	(mH)	0.1
Resonance Frequency	fs	(Hz)	1056
Mechanical Q factor	Qms		4.16
Electrical Q factor	Qes		1.13
Total Q factor	Qts		0.89
Mechanical resistance	Rms	(Kg/s)	0.38
Moving mass	Mms	(g)	0.24
Suspension compliance	Cms	(mm/N)	0.10
Effective cone diameter	D	(cm)	2.8
Effective piston area	Sd	(cm ²)	6.2
Force factor	Bl	(N/A)	3.1
Reference voltage sensitivity Re 2.83V 1m at 4190 Hz (Measured)		(dB)	91.5

Magnet and voice coil parameters:

Voice coil diameter	d	(mm)	26
Voice coil length	h	(mm)	1.6
Voice coil layers	n		2
Flux density in gap	B	(T)	1.5
Total useful flux		(mWb)	0.3
Height of the gap	hg	(mm)	3.0
Diameter of magnet	dm	(mm)	72
Height of magnet	hm	(mm)	15
Weight of magnet		(kg)	0.24

Power handling:

Long term Max System Power (IEC)		(W)	80
Max linear SPL (rms) / by power		(dB/W)	103/25

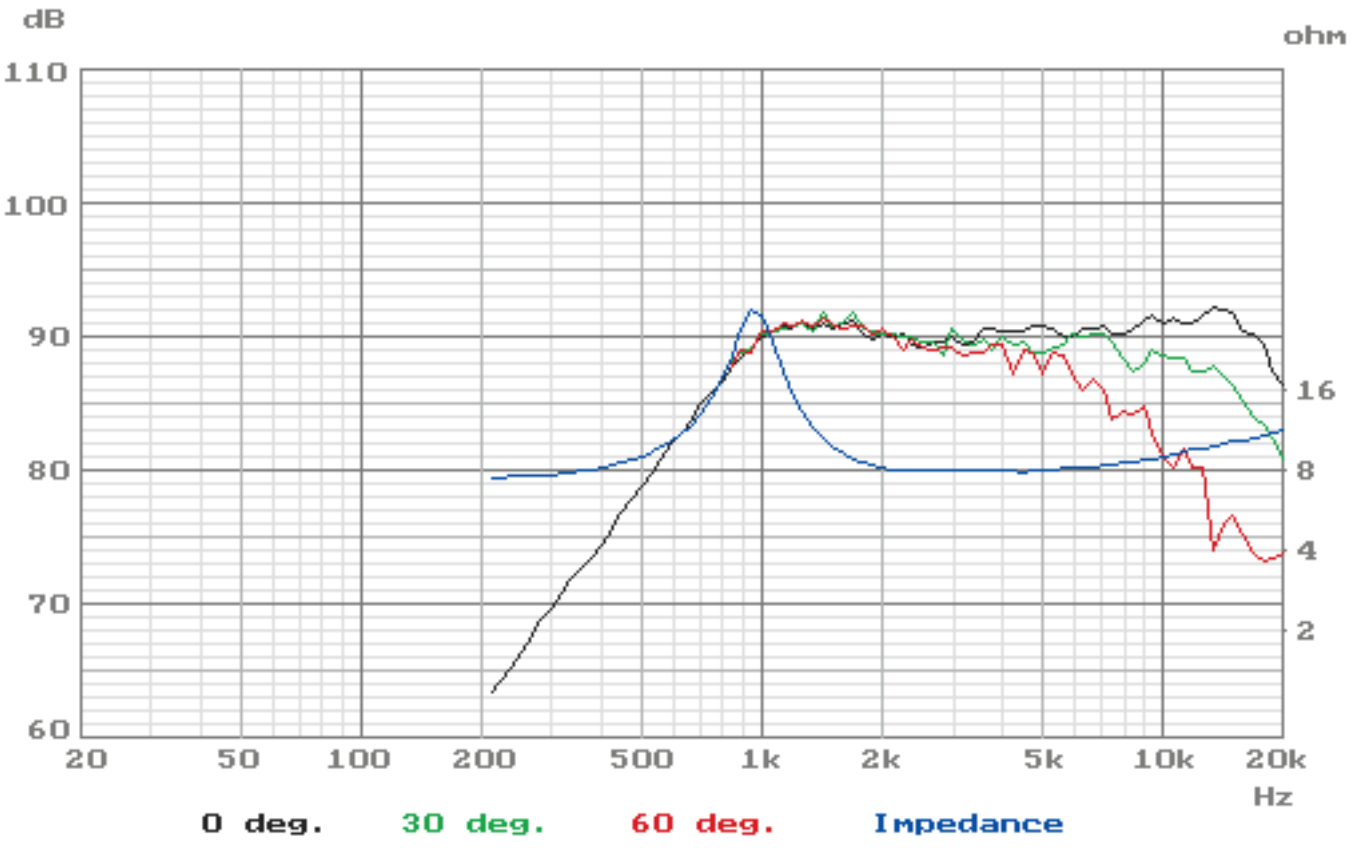

Measuring methods and conditions are stated in Peerless Standard for Acoustic Measurements (PSAM)